

TRAILER-MOUNTED STIRRER

AGC

TECHNICAL FEATURES

Wall version	Model			
	AGC1	AGC 3	AGC 5	AGC 7
Power (kW)	1.1	2.2	4.0	5.5
6-pole motor (RPM)	1000			
4-pole motor	1500			
2-pole motor	3000			
Ø Impeller	130/150		150/180	
Inverter	OPTIONAL			
Weight (kg)	350	380	420	450

TECHNICAL SPECIFICATIONS

- Ascent and descent controlled by gearmotor
- Top and bottom limit switches in the lifting trolley
- Power cables for moving components, in the chain
- Electrical control panel fitted on the machine, including
 - Main switch
 - Up and down selector
 - Start and stop buttons
 - Possible optimisation for speed adjustment, for models with inverter

STRUCTURAL FEATURES

- Large trolley in STAINLESS steel
- Stirring shaft in AISI 304 Stainless steel
- Ascent and descent by worm screw controlled by a 0.37 kW Gearmotor
- Shaft and impeller guard in stainless steel or, alternatively, perimeter guards in fired carbon steel with double safety switch
- Safety micro switches on minimum and maximum travel.

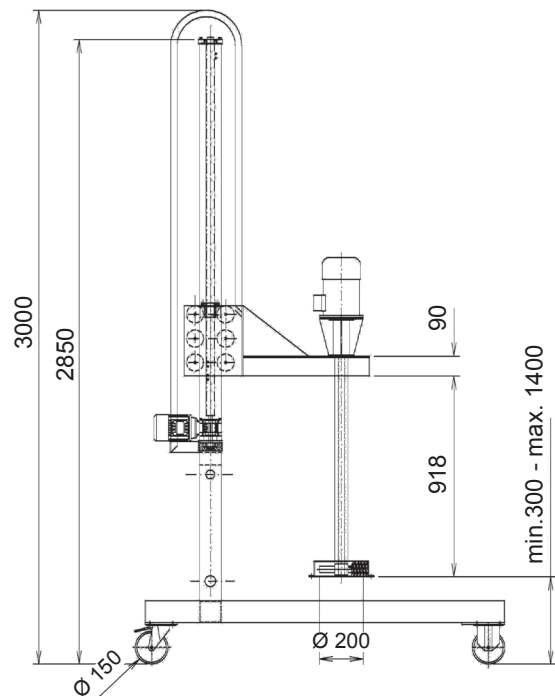
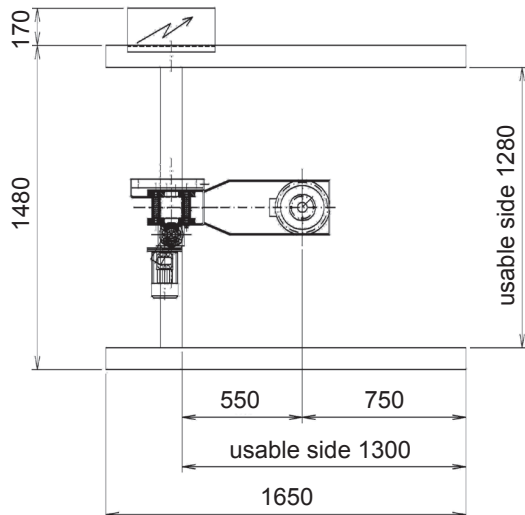

USE

- On glazing lines

ADVANTAGES

- High versatility due to the ease of movement and the possibility of mixing several tanks with a single unit

The information is approximate - The guaranteed values are released by Vibrotech s.r.l. on request - It is forbidden to reproduce the document even partially